

KNIFE GATE VALVES

KSC-A-W-.../...
Between flanges
DN50 - 1200, PN10

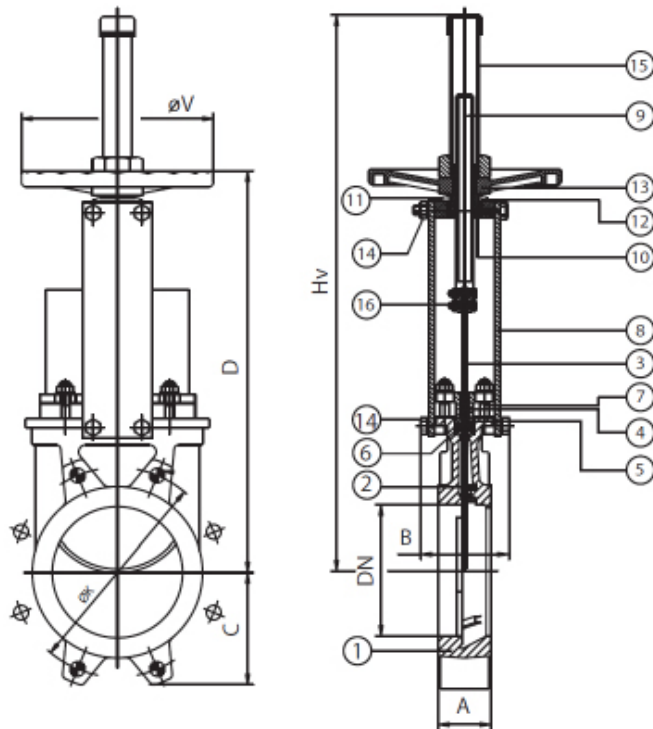

PARTS

No.	Part	Material	
		VII	XC
1	Body	GG25	CF8M
2	Guide	RCH 100	
3	Gate	304	316
4	Box bonnet	Aluminium	CF8M
5	Stuffing box	Synt/PTFE	
6	O-ring	EPDM	
7	Bolt	Teräs +Zn	316
8	Support	Steel	
9	Spindle	303	303/304
10	Stem nut	Bronze	
11	Nut	ST 44.2 + Zn	
12	Yoke	Steel	
13	Handwheel	GGG40	
14	Bolt / nut	Steel	
15	Hood	Steel	
16	Bolts / nuts	304	316

DIMENSIONS AND WEIGHTS

DN	A	B	C	D	ØV	Hv
50	40	92	63	289	185	409
65	40	92	70	316	185	436
80	50	92	92	342	185	462
100	50	92	105	382	185	502
125	50	102	120	415	225	585
150	60	102	130	458	225	637
200	60	119	160	575	325	815
250	70	119	198	676	325	1016
300	70	119	234	776	450	1116
350	96	290	256	906	450	1336
400	100	290	292	1012	450	1442
450	106	290	308	1098	450	1628
500	110	290	340	1210	450	1740
600	110	290	400	1416	450	2046
700	110	320	452	1611	620	2461
800	110	320	505	1870	620	2820
900	110	320	555	2103	800	3153
1000	110	320	610	2293	800	3443
1200	150	400	725			

OPTIONS

- » Position indicator
- » Positioner and limit switch
- » Locking
- » Rinsing combination
- » Worm drive
- » Pneumatic, hydraulic or electronic actuator
- » Control hole
- » Seal: EPDM, VITON, PTFE

DN	50	65	80	100	125	150	200	250	300	350	400	450	500	600	700	800	900	1000	1200
▲ P kg/cm ²	10	10	10	10	10	8	7	5	5	4	4	3	3	3	2	2	2	2	2
TORQUE	20	22	25	30	35	40	46	52	60	80	110	160	180	210	250	320	400	450	500